

Pearson's New Monopile Pier Design: Less Invasive. Less Costly. More Durable.



The attractive, eco-friendly solution to building strong, long-lasting piers.

If you are planning on building a new pier and dock, consider the new Pearson monopile design. It uses less material than traditional two-pile piers, and it is

less invasive on the eco-system because it requires half the penetrations into the earth.

Like all piers and docks built with Pearson Fiberglass Pilings, this monopile design is built to last. Pearson's advanced composites technology means that your pilings will never rot or rust like wood or steel. And they will never crumble like concrete.

Better yet, these innovative pilings are actually stronger than wood, steel or concrete pilings of similar diameters.*

Your new pier and dock will better withstand the forces of accidental impact and Mother Nature.

4-Foot Wide Assembly

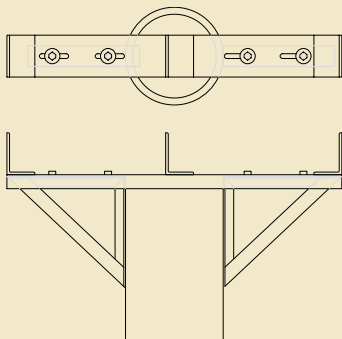

For more information including test data, visit
www.pearsonpilings.com or call 508-675-0594.

*See our "Load-to-Failure" calculation chart at www.pearsonpilings.com

Ideal for 4 to 6-foot wide piers up to 8 to 10-feet above ground plane

The Pearson monopile design takes advantage of the high strength of Pearson Fiberglass Pilings, allowing a single pile to take the place of two. A number of popular configurations has been calculated using Pearson's 14", 12" and 10" diameter fiberglass pilings. The larger the diameter piling used, the higher the elevation and the greater the expanse between pilings can be.

hardware is easy, and very little, if any, material is wasted.

Pearson's monopile design not only causes less disturbance to the environment, its fiberglass pilings do not contain any chemical preservatives, which may be harmful to the eco-system. The system is ideal for installation in ecologically sensitive areas and is especially cost-effective when there are long dis-

years. They'll never rot, rust, crumble or develop harmful, unsightly splinters. And, they're impervious to wood-boring insects and damage from marine growth. You'll never have to worry about replacing your pilings again.

Investing in a new monopile pier built with Pearson Fiberglass Pilings can not only increase the value of your waterfront property, you'll be applauded by

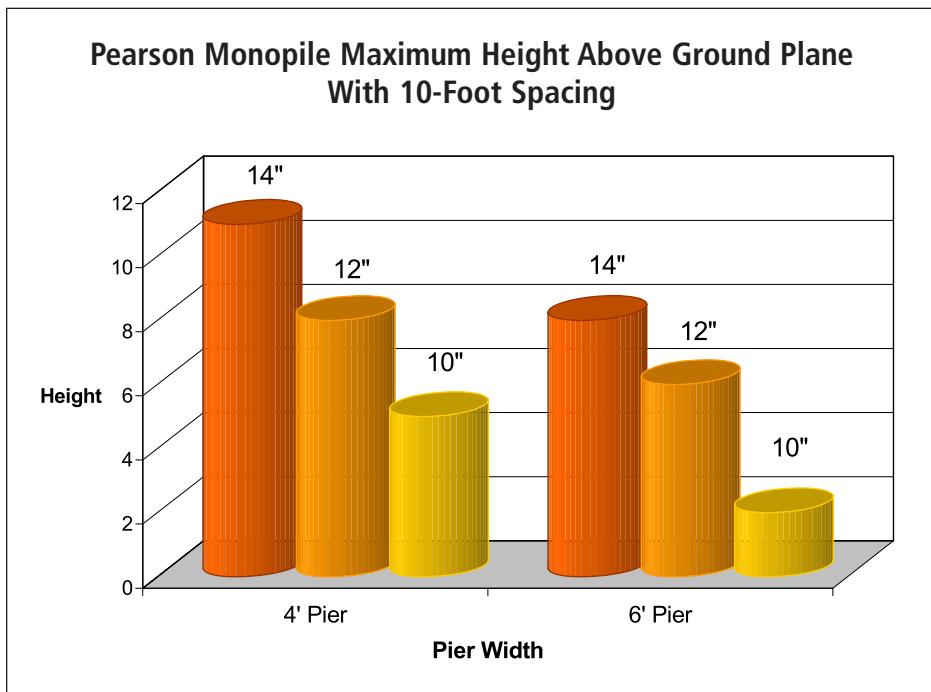

The monopile hardware is attached to the Pearson Fiberglass Piling with 3/4" galvanized bolts with dock washers. A 6"x 6" pressure treated cross beam is through-bolted to the monopile hardware.

Height recommendations are based on pilings being driven to proper resistance and depth.

Spans between pilings of up to 15-feet at a height of up to 9-feet are possible using Pearson's 14" diameter pilings.

After driving the piles, installation of

tances from the shore to the dock.

Pearson Fiberglass Pilings feature a smooth, natural brown protective coating that will look good for years and

environmentalists for your choice of our eco-friendly design and preservative-free material.

Ask your marine contractor to quote your job using today's strongest, best looking, longest lasting material – Pearson Fiberglass Pilings.

Detailed Height Recommendations and Assembly Drawings Available

Send for detailed construction drawings or visit our Web site at www.pearsonpilings.com.

